



Farming Hopper

Hopper from BDW are dosing bins which are used for the storage and dosing of small amounts of dry minerals, pre-mixes and other feed additives. The hopper are available as Type T100 and T160. The discharge from the hopper is made either via a 75 helix or a 100 auger. Above all mineral mixtures with a high fat content can be better conveyed with an auger. The angle of the auger can be set variably from 0° to 60°. With a spiral a capacity of 1.1 t/h is achieved, with an auger, depending upon the pitch, between 3.9 and 7.3 t/h. A safety grid is included in the scope of supply.

Hopper with agitators from BDW are especially well suited for light, slow flowing and difficult to discharge bulk materials such as fish meal etc., due the floor mounted agitator, which pushes the bulk material into the screw chutes.

All advantages at a glance

- Due to the two vertical sides and an open screw conveyor throughout the entire length of the hopper, the risk of bridging is very low
- Available in galvanized or stainless steel, depending on the aggressiveness of the material
- Additional equipment:
Cover, grate for Big Bags, extension for T100 and T160





Farming

Hopper

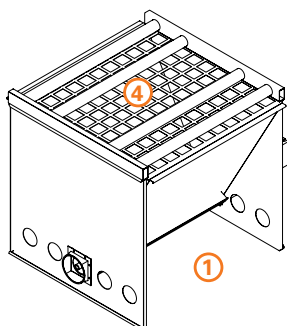
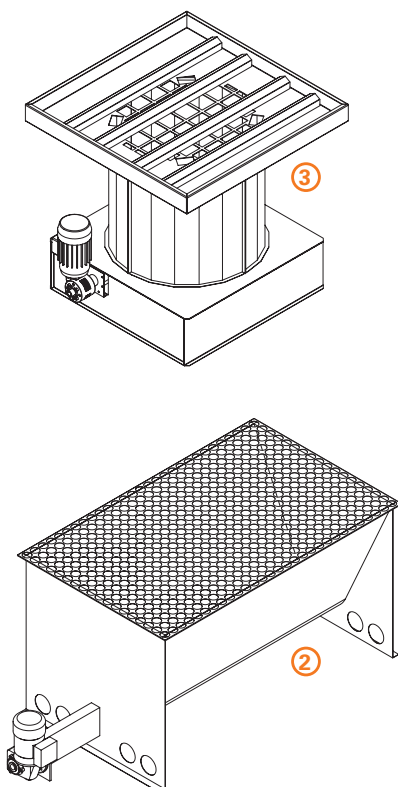

Type	Volume, m ³
Hopper T100	0.5
Hopper T160	0.65
Hopper with agitator	0.45

Item	Description
1	Hopper T100
2	Hopper T160
3	Hopper with agitator
4	Grate for Big Bags

